

## Sandy Inox

Electrical submersible sludge pump

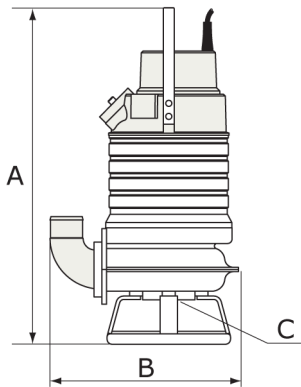

50 Hz	Sandy Inox
Discharge connection	3"
Rated power $P_2$ [kW]	6,3
Max. power consumption $P_1$ [kW]	7,3
Shaft speed [r.p.m.]	2840
Rated current at 400V	12 A
Rated current at 500V	9,4 A
Solids passage	46 mm
Dimensions A / B / C	755 / 480 / 46 mm
Weight	86 kg

Other voltages on request

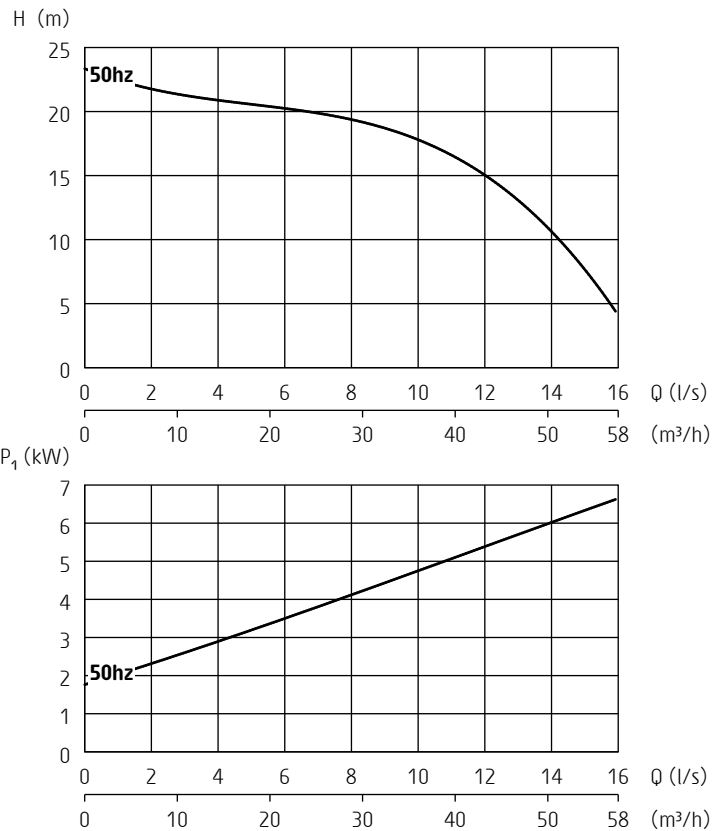

ISO 9906/A

### General description

Submersible sludge pump made of stainless steel for mines, processing industries and salt-water applications

### Classification

Electrical submersible pump  
Protection class: IP 68

### Electrical motor

Squirrel cage induction motor  
Insulation class: F (IEC 85)

### Motor protection

Phase sequence control, phase failure guard, temperature guard with thermal contacts in the stator (= SMART system). Air valve

### Cable - SubCab 20 m (66 ft)

50 Hz 380 - 500V: 4G2.5mm<sup>2</sup>  
60 Hz 230: 4G4mm<sup>2</sup> - AWG12/4  
60 Hz 460 - 575V: 4G2.5mm<sup>2</sup> - AWG14/4

### Limitations

Max. submersion depth: 20 m (66 ft)  
Max. liquid temperature: 40 °C (104 °F)  
Allowed pH range: 2 - 10  
Maximum liquid density: 1100 kg/m<sup>3</sup> (68 lbs/ft<sup>3</sup>)

### Shaft seals

Double mechanical shaft seals running in an oil compartment  
Material lower seal: silicon carbide - silicon carbide  
Material upper seal: carbon - silicon carbide

### Bearings

Ball bearings with C3 clearance

### Discharge connection

3" hose, Iso-G BSP or NPT

### Materials

Casted parts: *Stainless steel (EN 10283-1.4412-ASTM CF-8M)*  
Outer casing: *Stainless steel (EN 10088-3-1.4436-AISI 316L)*  
Motor shaft: *Stainless steel (EN 10088-3-1.4460-AISI 329)*  
Impeller: *Stainless steel (EN 10283-1.4412-ASTM CF-8M)*  
Screws and nuts: *Stainless steel (A4)*  
O-rings: *Viton rubber*  
Pump housing liner: *Nitrile rubber*

### Accessories

Zinc anodes

Specifications can be changed without notice